

TMFSS MINI S E R I E S

Compact And Portable Machinery Fault Signature Simulator For Learning Machine Fault Diagnosis

MACHINERY FAULT SIGNATURE SIMULATORS

Faults such as unbalanced rotors, misaligned shafts, cracked bearing races, broken gear teeth, eccentricity in belts, rubbing, looseness in foundations, mechanical & electrical faults in induction motors, blade hitting and rubbing, etc. are common in the industry. TMFSS is a useful tool for simulating the fault signatures of components of industrial machinery. These test benches provide a platform for the users to simulate the above faults in a test environment for learning / sensor prototype testing & qualification / developing algorithms for predictive or preventive maintenance/research on signature feature extraction & signal processing techniques etc.

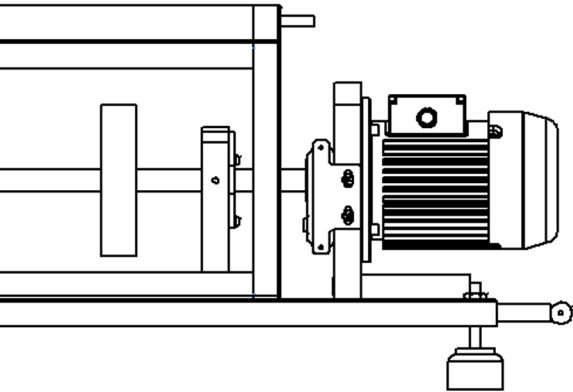

TMFSS MINI

The Mini-Series is a portable and compact version of the TMFSS, simulates 7+machinery faults. This model is widely used for sensor prototype testing and qualification, developing machine learning algorithms & signal processing techniques, hands-on training & skill upgradation for maintenance personnel, etc.

ABOUT TIERA

TIERA is a company working in the domains of vibration testing, training, Test and measurement System development & sales. The company has been manufacturing the simulators for 5+ years, delivering cost-effective test benches without compromising the quality. It is backed by a team of experts in Vibration testing, Mechanical & Electronics domain product development, and Software development. We have developed customized test benches for customers in the past, for research organizations like Vikram Sarabhai Space Centre, Trivandrum & Academic Research Institutions like the National Institute of Technology Silchar, Assam, etc. based on their requirements.

LIST OF EXPERIMENTS

- Static and dynamic unbalance simulation and subsequent waveform, frequency analysis and order spectrum analysis with Phase measurements.
- Study of unbalance of the multi-rotor system and overhanging rotors.
- Single plane and dual plane balancing techniques.
- Order spectrum, order tracking, and orbit plots.
- Misalignment studies using frequency spectrum, order spectrum and phase analysis.
- Run up and coast down test with waterfall plots.
- Modal testing and ODS with cross-channel measurements.
- Bump testing.
- Bearing condition monitoring using demodulation and enveloping.
- Blade pass frequencies and blade rub effects.
- Foundational Looseness.
- Rubbing Effects.
- Gear box faults.
- Induction motor faults.
- Pump Cavitation

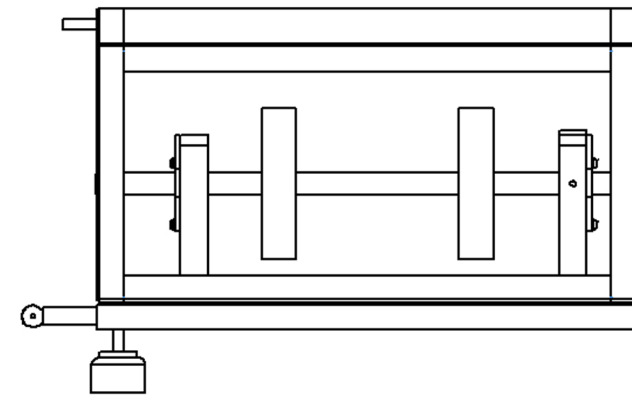

SPECIFICATIONS

Electrical

Motor & Drive	0.5 HP three-phase induction motor with VFD drive & EMI/EMC Filters for speed control with control Panel
Max RPM	Maximum speed of 3000RPM
Power Supply	230 V AC, Single Phase 50 Hz

Mechanical

Shaft Diameter	20 mm diameter turned, ground and polished (TGP) stainless steel shaft.
Bearing	Deep groove bearings are used. Two bearing blocks (aluminum alloy) with drilled holes for varying the rotor span. Bearing adapters fitted with faulty ones helps in mounting faulty/ Healthy. Dowel pins can be provided (if required) for accurate alignment.
Base & Foundation	350X 25.4X 700 (B X T X L), powder coated aluminum-alloy base plate. Mounting holes fitted with Heli coil inserts for repeated mounting/detaching. Alternate holes are provided for adjusting the effective distance between bearing mounts. Proper damping pads are provided for isolation. Stiffening is provided to avoid resonances.
Rotors	Two Anodized Aluminum discs 140 mm X 32mm (Dia X T) with evenly spaced holes at the sides for adding weights for simulating and correcting unbalance.
Mounts for Sensors	Mounting pads for magnetic base at bearing housing and motor housing. Slotted plates for placing tachometer and proximity probes
Safety Features	Acrylic cover & Emergency Stop button for extra safety.

MODELS

TMFSS Models

Fault Type	Ordering Code	Option 1	Option 2	Option 3
Unbalance	UB	✓	✓	✓
Basic Misalignment (Shims)	BM	✓	✓	✓
Advance Misalignment (Jack Bolt)	AM		✓	✓
Bearing Fault	BF	✓	✓	✓
Foundation Looseness	FL	✓	✓	✓
Coupling Studies	COS			✓
Rotor Rub	RR	✓	✓	✓
Cocked Bearing	CB		✓	✓
Bent Shaft	BS	✓	✓	✓
Finned Rotor	FR	✓	✓	✓
Eccentric Rotor	ER		✓	✓
Cocked Rotor	CR		✓	✓
Add-on Attachments *				
Straight Bevel gear Fault	SBG			✓
Sleeve Bearing	SB			✓
Electrical Motor Fault	EMF			✓
Pump Cavitation	PC			✓
Accelerated Bearing Wear kit	ABW			✓
Lockable Bearing Kit	LB			✓

Options 1&2 can be configured as per requirement.

TMFS Simulator: A Sneak Peek

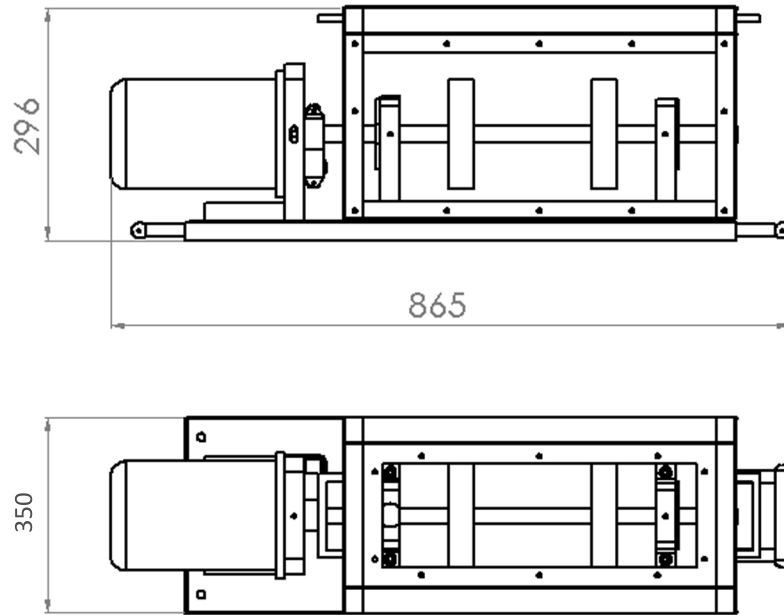

**Please note the specifications depend on the model , the specifications and the parts shown in the brochure are for reference only and are subject to change

TMFS Simulator: A Sneak Peek

CONTROL PANEL

- Manual mode for direct control/ Wifi Mode for remote Control.
- Operate from a safe distance.
- Ramp up / Coast down test options
- In-built RPM display unit
- Emergency Stop Button
- Detachable from the main unit
- Plug & Play

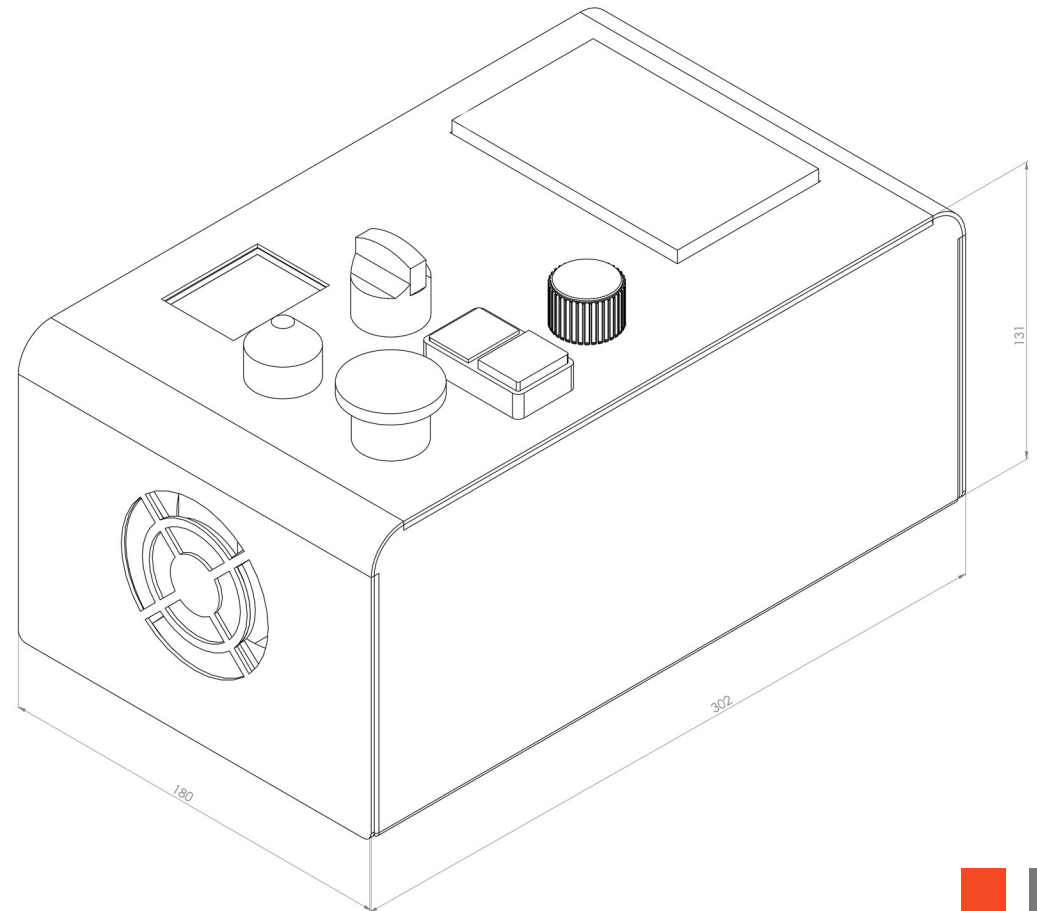

**Please note the specifications depend on the model , the specifications and the parts shown in the brochure are for reference only and are subject to change

TMFS Simulator: A Sneak Peek

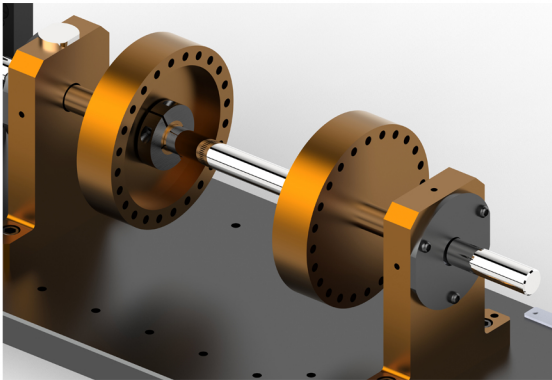

ROTOR DISC

- Learn the effects of rotor unbalance on vibration spectra.
- Learn static, dynamic, and overhanging unbalance conditions.
- Learn Single and Dual plane balancing.

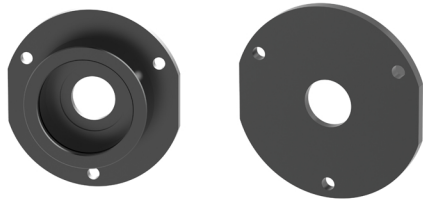

BEARING ADAPTER

- Learn fault signature from different stages of bearing faults.
- Calibrated fault of slight or hair line fault, Medium and Severe ranges of Faults can be studied to find the effects on vibrations
- Learn Signal Processing techniques for Bearing Fault detection like envelope, Cepstrum analysis etc

TMFS Simulator: A Sneak Peek

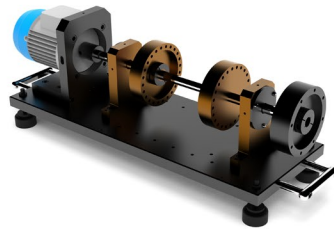

BEARING LOADER

- To investigate the effects of radial loading.
- Enhance the spectral amplitude of the system
- To simulate a practical case of a machine with radial loading.

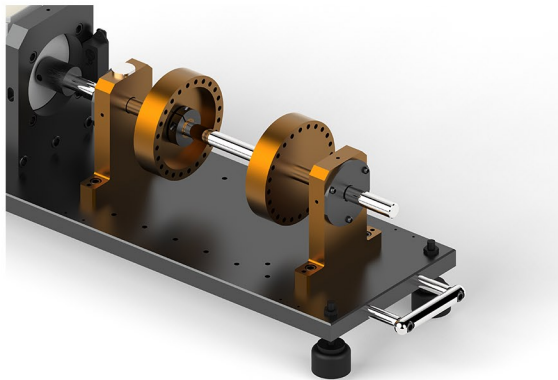

BENT SHAFT

- Learn the signature vibration from bent shaft system.
- Learn to distinguish between bent shaft, misalignment and unbalance using spectrum and phase measurements.

TMFS Simulator: A Sneak Peek

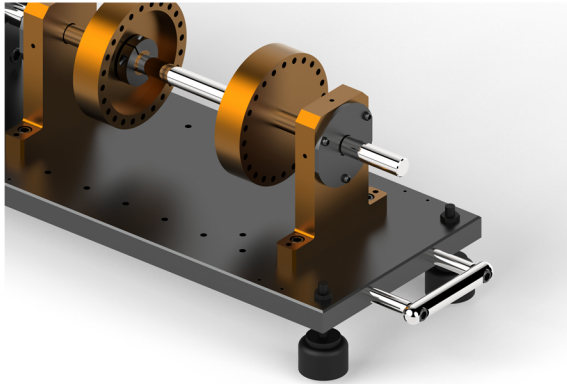

COCKED BEARING

- Learn the importance of proper bearing installation.
- Learn to detect a bearing which has been mounted defectively from vibration spectra and phase measurement.
- To realise the importance of measurement directions in identifying faults.

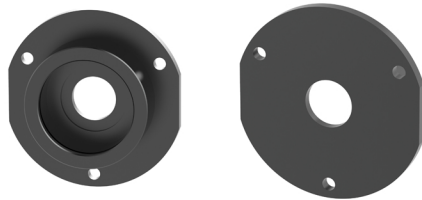

SLEEVE BEARINGS

- Learn to detect looseness in sleeve bearings and to perform orbit analysis using eddy current probes

TMFS Simulator: A Sneak Peek

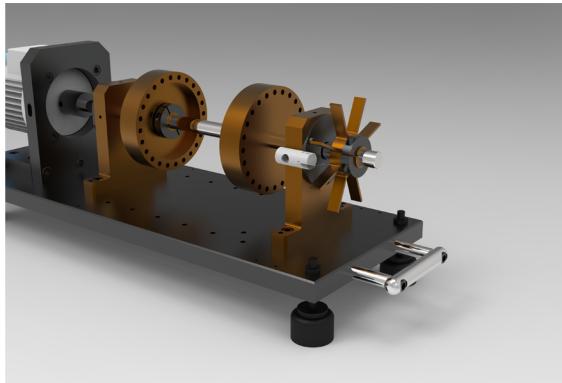

FIN/BLADES

- Learn to detect Blade Pass frequency
- Understand the effects of eccentric mass/hole on blades.

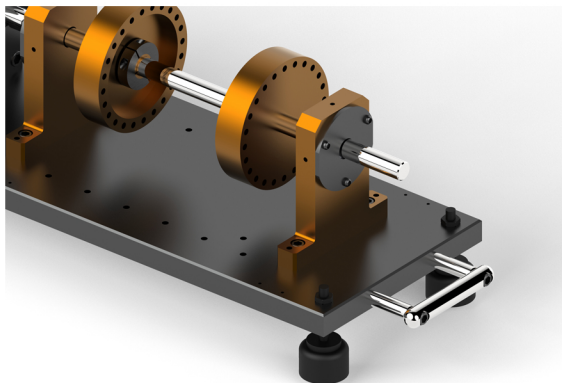

RUB ATTACHMENT & FOUNDATION LOOSENESS

- Learn the effects of rubbing and looseness in vibration signature especially the spectra.

TMFS Simulator: A Sneak Peek



PUMP CAVITATION

- Learn to detect pump cavitation through vibration Acoustic signatures

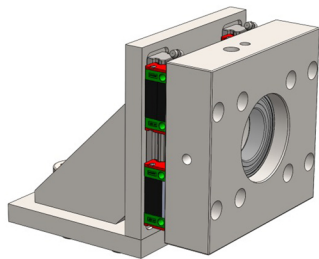

ACCELERATED BEARING WEAR ATTACHMENT

- To learn the bearing failure signature as a function of load and rotational speed.
- Learn the effect of loading in bearings.

TMFS Simulator: A Sneak Peek

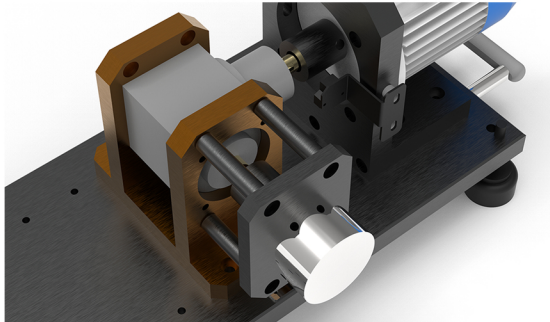

GEAR BOX

- Learn to detect broken tooth crack in straight bevel gear or spur gears.
- Learn signal processing techniques for extracting gear fault signatures.



ELECTRICAL FAULTS

- Learn to detect electric motor faults such as Phase Voltage unbalance, Open Circuit fault and rotor bar defect etc.

TMFS Simulator: A Sneak Peek

Add-ons

Details	Code
IEPE Data Acquisition System	
2 IEPE Channels , Simultaneous , Max 48 Kilo Samples/s	Phono vibe-D
4 IEPE Channels , Simultaneous , Max 64 Kilo Samples/s	Phono vibe-Q
8 IEPE Channels , Simultaneous , Max 64 Kilo Samples/s	Phono vibe-O
Software Options	
TVIB Sound & Vibration Analysis Modules	
Time & FFT Spectrum Analyzer with Postprocessor	TSAP 201
Basic Vibration meter	TVM202
Advanced Vibration meter	TVM203
Sound level meter	TSLM 204
FRF Test	TIST 205
Waveform Generator	TWGM 206
Order Analysis Basic	TOA 207
Order Analysis Advanced	TOA 208
Balancing Basic	TB 209
Balancing Advanced	TB 210
Human Vibration meter	THVM 211
Orbit Analysis	TO 212
Sensors	
Proximity Probe Kit: Eddy current probe, Driver and Cable 5 meter, Mounting Accessories	ECP 100
Accelerometer kit: IEPE Accelerometer, Cable 3 meter, Mounting Accessories	VA 101
Microphone kit: IEPE Microphone, Cable 3 meter, Holder	AA 102
Bearing Load cells	BL 103
Static Load Measurement Unit	LM 104
Modal Analysis Kit	
Impact Hammer, Impedance Head, Electrodynamic Shaker, Amplifier, Signal Generator, Software	MA 300
Training	
Vibration Analysis based on ISO 18436 CAT I, CAT II	CVA 300
Experimental Modal Analysis: A Practical Approach	CEMA 301
TOLean VIBE Simulator Software	TOL 302

CUSTOMERS



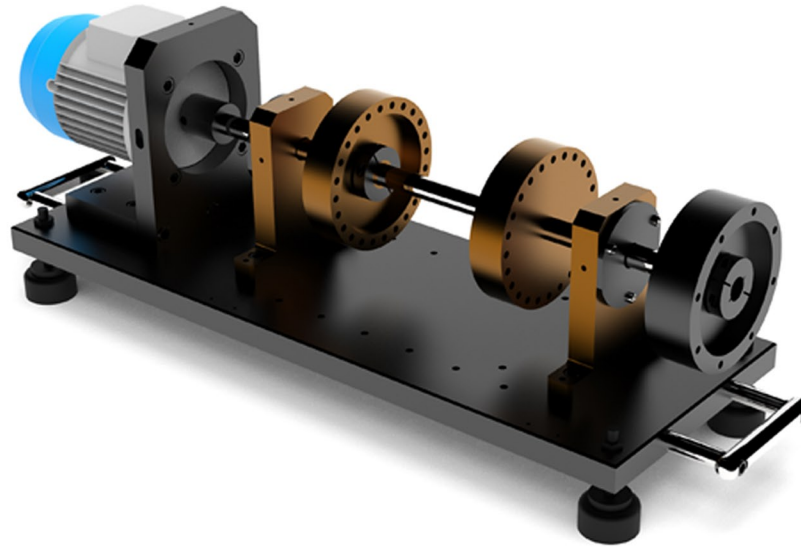

CONTACT US

Tyrannus Innovative Engineering and Research Academy Pvt. Ltd.

TrEST Research Park, TC- 4/2322, GEM building, (Opp) CET Thiruvananthapuram, Kerala
695016

GSTIN: 32AAFCT7371M1ZY

sales@tieraonline.in

www.tieraonline.in