

30 + Machinery Fault Simulator



TMFSS MACRO

SERIES



MACHINERY FAULT SIGNATURE SIMULATORS

Faults such as unbalanced rotors, misaligned shafts, cracked bearing races, broken gear teeth, eccentricity in belts, rubbing, looseness in foundations, mechanical & electrical faults in induction motors, blade hitting and rubbing, etc. are common in the industry. TMFSS is a useful tool for simulating the fault signatures of components of industrial machinery. These test benches provide a platform for the users to simulate the above faults in a test environment for learning / sensor prototype testing & qualification / developing algorithms for predictive or preventive maintenance/research on signature feature extraction & signal processing techniques etc.

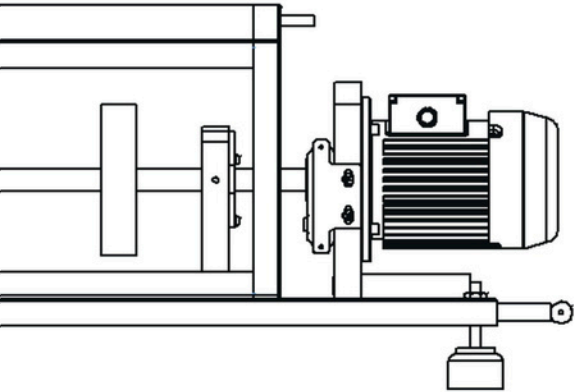

TMFSS

The Macro-Series is a portable and compact version of the TMFS, simulates 10+ machinery faults. This model is widely used for sensor prototype testing and qualification, developing machine learning algorithms & signal processing techniques, hands-on training & skill upgradation for maintenance personnel, etc.

ABOUT TIERA

TIERA is a company working in the domains of vibration testing, training, Test and measurement System development & sales. The company has been manufacturing the simulators for 5+ years, delivering cost-effective test benches without compromising the quality. It is backed by a team of experts in Vibration testing, Mechanical & Electronics domain product development, and Software development. We have developed customized test benches for customers in the past, for research organizations like Vikram Sarabhai Space Centre, Trivandrum & Academic Research Institutions like the National Institute of Technology Silchar, Assam, etc. based on their requirements.

LIST OF EXPERIMENTS

- Static and dynamic unbalance simulation and subsequent waveform, frequency analysis and order spectrum analysis with Phase measurements.
- Study of unbalance of the multi-rotor system and overhanging rotors.
- Single plane and dual plane balancing techniques.
- Order spectrum, order tracking, and orbit plots.
- Misalignment studies using frequency spectrum, order spectrum and phase analysis.
- Run up and coast down test with waterfall plots.
- Modal testing and ODS with cross-channel measurements.
- Bump testing.
- Bearing condition monitoring using demodulation and enveloping.
- Blade pass frequencies and blade rub effects.
- Foundational Looseness.
- Bent Shaft Studies
- Shaft Crack Studies
- Effect of Dampening provision in bearing house
- Rubbing Effects
- Reciprocating mechanism studies
- Belt drive faults
- Gear box faults
- Induction motor faults

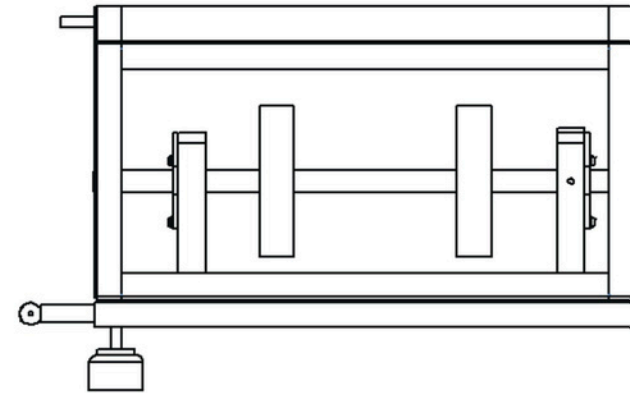

SPECIFICATIONS

Electrical

Motor & Drive	<p>1 HP 3-Phase AC Motor; Position Adjustable</p> <ul style="list-style-type: none">- Motor Controller Unit: Easy to use, portable, plug and play control unit- Manual/ Wifi Option for Motor Speed Control; Wifi control via PC/Mobile; Options for Ramp up/Coast Down in Wifi Mode- For controlling the speed of the Machine- Start/ Stop control button.- FWD/Rev Direction Switch- Emergency stop-button for Safety <p>1 HP Single Phase VFD Drive with EMI/ EMC filters; Monitor VFD parameters such current consumption power, voltage etc. and option for configuring VFD parameters via PC Software.</p> <p>In built Laser Speed Sensor; LCD RPM Display; Analog TTL Output Signal</p>
Max RPM	Maximum speed of 6000 RPM
Power Supply	230 V AC, Single Phase 50 Hz

Mechanical

Shaft Diameter	<p>20 mm diameter turned, ground and polished (TGP) stainless steel shaft</p> <p>15 mm diameter turned, ground and polished (TGP) stainless steel shaft</p>
Bearing Housing	<p>Deep groove bearings are used. Two bearing blocks (aluminum alloy) with drilled holes for varying the rotor span.</p> <p>Bearing adapters fitted with faulty ones helps in mounting faulty/ Healthy. Dowel pins can be provided (if required) for accurate alignment.</p>
Base & Foundation	<p>1200x 500 x 25 mm (approx.) Anodized Aluminum base with predrilled holes for easy mounting of various kits.</p> <p>Mounting holes fitted with Heli coil inserts for repeated mounting/detaching. Alternate holes are provided for adjusting the effective distance between bearing mounts.</p>
	<p>Anti-vibration Mount for Isolation. Stiffening of base is provided to avoid resonances.</p>
Rotors	<p>Two Anodized Aluminum discs with evenly spaced holes at the sides for adding weights for simulating and correcting unbalance.</p>
Mounts for Sensors	<p>Mounting pads for magnetic base at bearing housing and motor housing.</p> <p>Slotted plates for placing Speed Sensor and proximity probes (optional)</p>
Safety Features	<p>Acrylic cover for Safety and Visibility</p> <p>Emergency Stop button</p>

MODELS

TMFSS Models

Fault Type	Ordering Code	Option 1	Option 2	Option 3
Basic	BAS	✓	✓	✓
Faults included				
a. Unbalance Simulation				
b. Misalignment Simulation				
c. Bearing Fault Simulation attachments (excl. Cocked Bearing)				
d. Foundation Looseness				
Add-on Attachments *				
Resonance Simulation Kit	RS		✓	✓
Coupling Studies	COS		✓	✓
Mechanical Rub	RR		✓	✓
Cocked Bearing	CB		✓	✓
Bent Shaft	BS		✓	✓
Finned Rotor	FR		✓	✓
Eccentric & Cocked Rotor	ECR		✓	✓
Belt Drive Fault	BDF		✓	✓
Cracked Shaft	CRS		✓	✓
Reciprocating Mechanism	RM		✓	✓
Damping	DA		✓	✓
Sleeve Bearing	SB		✓	✓
Gear Box Fault	GBF		✓	✓
Electrical Motor Fault	EMF		✓	✓
Sleeve Bearing	SB		✓	✓
Pump Cavitation	PC			✓
Accelerated Bearing Wear kit	ABW			✓
Lockable Bearing Kit	LB			✓

* Options 1 & 2 can be configured as per requirement.

TMFS Simulator: A Sneak Peek

CONTROL PANEL

- Manual mode for direct control/ Wifi Mode for remote Control.
- Operate from a safe distance.
- Ramp up / Coast down test options
- In-built RPM display unit
- Emergency Stop Button
- Detachable from the main unit
- Plug & Play

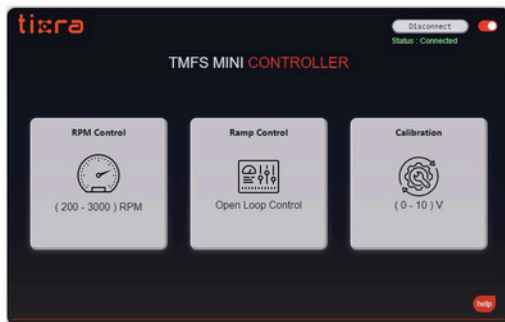

**Please note the specifications depend on the model , the specifications and the parts shown in the brochure are for reference only and are subject to change

TMFS Simulator: A Sneak Peek

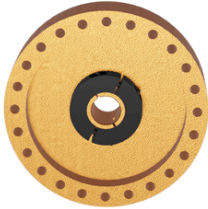

ROTOR DISC

- Learn the effects of rotor unbalance on vibration spectra.
- Learn static, dynamic, and overhanging unbalance conditions.
- Learn Single and Dual plane balancing.

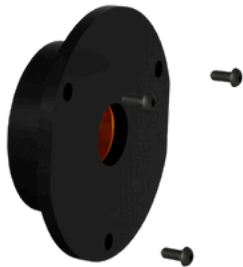

BEARING ADAPTER

- Learn fault signature from different stages of bearing faults.
- Calibrated fault of slight or hair line fault, Medium and Severe ranges of Faults can be studied to find the effects on vibrations
- Learn Signal Processing techniques for Bearing Fault detection like envelope, Cepstrum analysis etc

TMFS Simulator: A Sneak Peek



BEARING LOADER

- To investigate the effects of radial loading.
- Enhance the spectral amplitude of the system
- To simulate a practical case of a machine with radial loading.

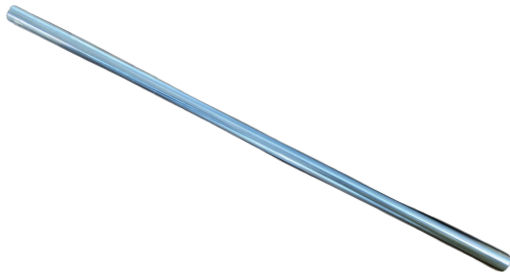

BENT SHAFT

- Learn the signature vibration from bent shaft system.
- Learn to distinguish between bent shaft, misalignment and unbalance using spectrum and phase measurements.

TMFS Simulator: A Sneak Peek

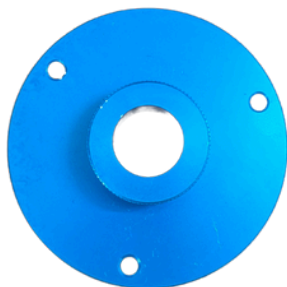

COCKED BEARING

- Learn the importance of proper bearing installation.
- Learn to detect a bearing which has been mounted defectively from vibration spectra and phase measurement.
- To realise the importance of measurement directions in identifying faults.



SLEEVE BEARINGS

- Learn to detect loosenes in sleeve bearings and to perform orbit analysis using eddy current probes

TMFS Simulator: A Sneak Peek



FIN/BLADES

- Learn to detect Blade Pass frequency
- Understand the effects of eccentric mass/hole on blades.



RUB ATTACHMENT & FOUNDATION LOOSENESS

- Learn the effects of rubbing and looseness in vibration signature especially the spectra.

TMFS Simulator: A Sneak Peek

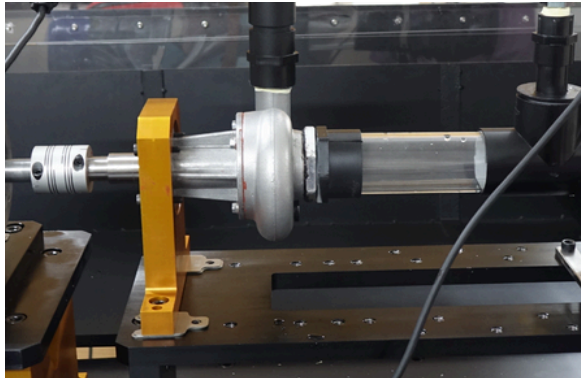

PUMP CAVITATION

- Learn to detect pump cavitation through vibration Acoustic signatures

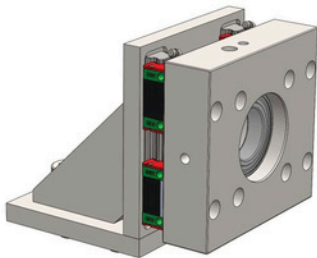

ACCELERATED BEARING WEAR ATTACHMENT

- To learn the bearing failure signature as a function of load and rotational speed.
- Learn the effect of loading in bearings.

TMFS Simulator: A Sneak Peek

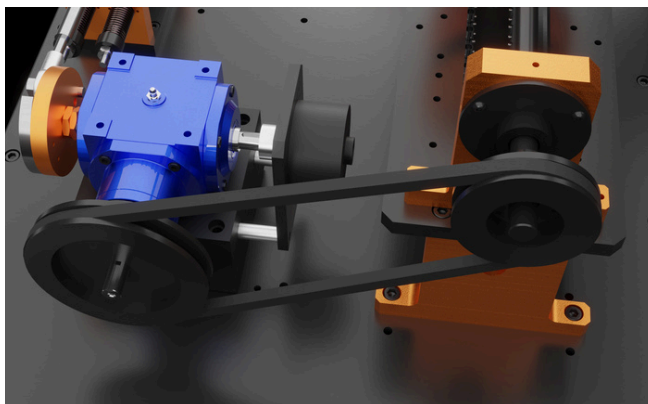

GEAR BOX

- Learn to detect broken tooth crack in straight bevel gear or spur gears.
- Learn signal processing techniques for extracting gear fault signatures.

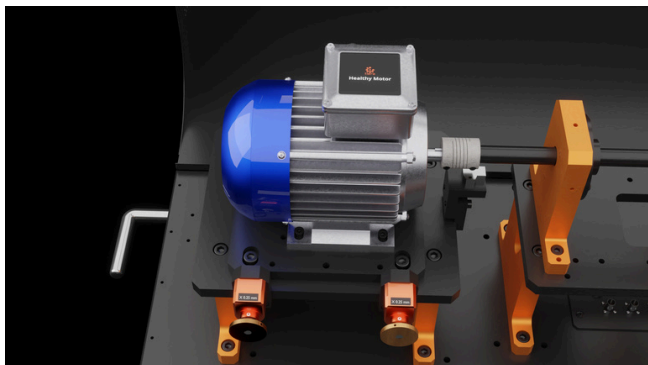

ELECTRICAL FAULTS

- Learn to detect electric motor faults such as Phase Voltage unbalance, Open Circuit fault and rotor bar defect etc.

TMFS Simulator: A Sneak Peek

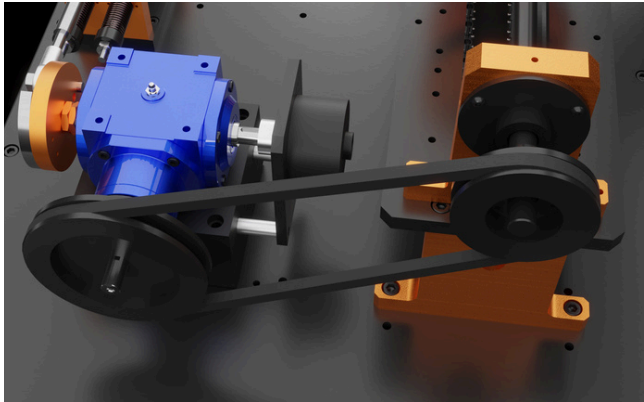

BELT DRIVE

- For learning the faults associated with pulley and belt drive for simulating following faults:
- Belt Misalignment
- Belt Tensioner assembly with suitable sheaves and belts
- Eccentric Sheave
- Sheave unbalance
- Belt Resonance

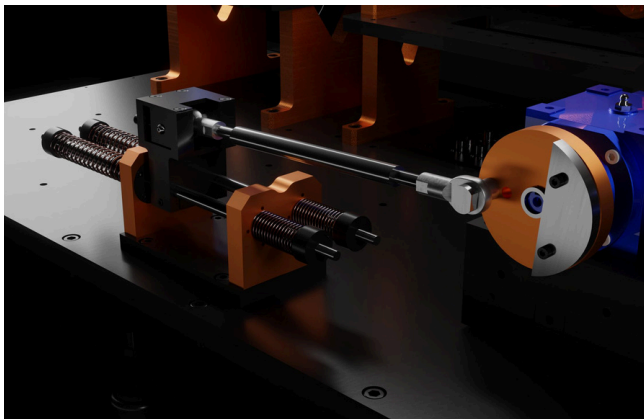

Reciprocating Mechanism

- Investigation of the vibrations of crank drives
- Crank drive with adjustable stroke
- Interchangeable bearing bushes permit simulation of bearing clearance
- Springs simulate gas forces

TMFS Simulator: A Sneak Peek

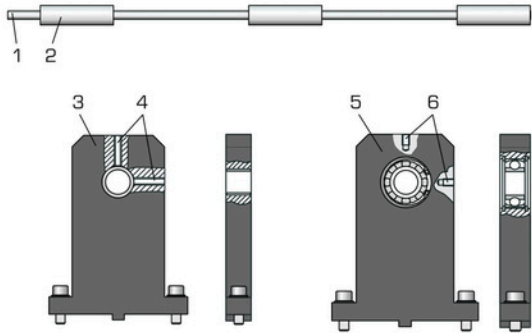

Resonance Kit

- Investigation of flexural vibration of an elastic shaft
- Stainless steel elastic shaft
- Bearing blocks and safety bearing with bores for sensor mounting



Cracked Shaft

- Investigation of the vibration behaviour of a cracked shaft
- Crack adapter in flange form
- Simulation of the crack by opening bolt joints

TMFS Simulator: A Sneak Peek

Add-ons

Details	Code
IEPE Data Acquisition System	
2 IEPE Channels , Simultaneous , Max 48 Kilo Samples/s	Phono vibe-D
4 IEPE Channels , Simultaneous , Max 64 Kilo Samples/s	Phono vibe-Q
8 IEPE Channels , Simultaneous , Max 64 Kilo Samples/s	Phono vibe-O
Software Options	
TVIB Sound & Vibration Analysis Modules	
Time & FFT Spectrum Analyzer with Postprocessor	TSAP 201
Basic Vibration meter	TVM202
Advanced Vibration meter	TVM203
Sound level meter	TSLM 204
FRF Test	TIST 205
Waveform Generator	TWGM 206
Order Analysis Basic	TOA 207
Order Analysis Advanced	TOA 208
Balancing Basic	TB 209
Balancing Advanced	TB 210
Human Vibration meter	THVM 211
Orbit Analysis	TO 212
Sensors	
Proximity Probe Kit: Eddy current probe, Driver and Cable 5 meter, Mounting Accessories	ECP 100
Accelerometer kit: IEPE Accelerometer, Cable 3 meter, Mounting Accessories	VA 101
Microphone kit: IEPE Microphone, Cable 3 meter, Holder	AA 102
Bearing Load cells	BL 103
Static Load Measurement Unit	LM 104
Modal Analysis Kit	
Impact Hammer, Impedance Head, Electrodynamic Shaker, Amplifier, Signal Generator, Software	MA 300
Training	
Vibration Analysis based on ISO 18436 CAT I, CAT II	CVA 300
Experimental Modal Analysis: A Practical Approach	CEMA 301
TOLean VIBE Simulator Software	TOL 302

CUSTOMERS

Honeywell

SCHAEFFLER

CYIENT

LAB³



CHENNAI INSTITUTE OF TECHNOLOGY (Autonomous)



ADVANTECH

CIMCON Software



SOMAIYA VIDYAVIHAR UNIVERSITY

VIBROSINE
Helping You Understand the Sign of Your Sine



CONTACT US

Tyrannus Innovative Engineering and Research Academy Pvt. Ltd.

TrEST Research Park, TC- 4/2322, GEM building, (Opp) CET Thiruvananthapuram, Kerala
695016

GSTIN: 32AAFCT7371M1ZY

sales@tieraonline.in

www.tieraonline.in